

Data Sheet – PTFE Clear Expansion Joint Guards

Ideal for Acid / Caustic / E115 Oil and Diesel mist prevention

The PTFE-Clear shield is manufactured from Teflon coated fibreglass, with wide central band of clear Teflon (ECTFE). This permits visual inspection of the expansion joint. Stitching is Teflon coated glass thread.

The easy to fit, lock tight, fastening system comprises a Velcro strip coupled with a braided 100% Teflon coated fibreglass draw string. When tightened the fabric is drawn over the flange bolts toward the pipe wall thus eliminating a lateral spray out.

For a detailed quotation please confirm key dimensions "A" "B" & "C" below.

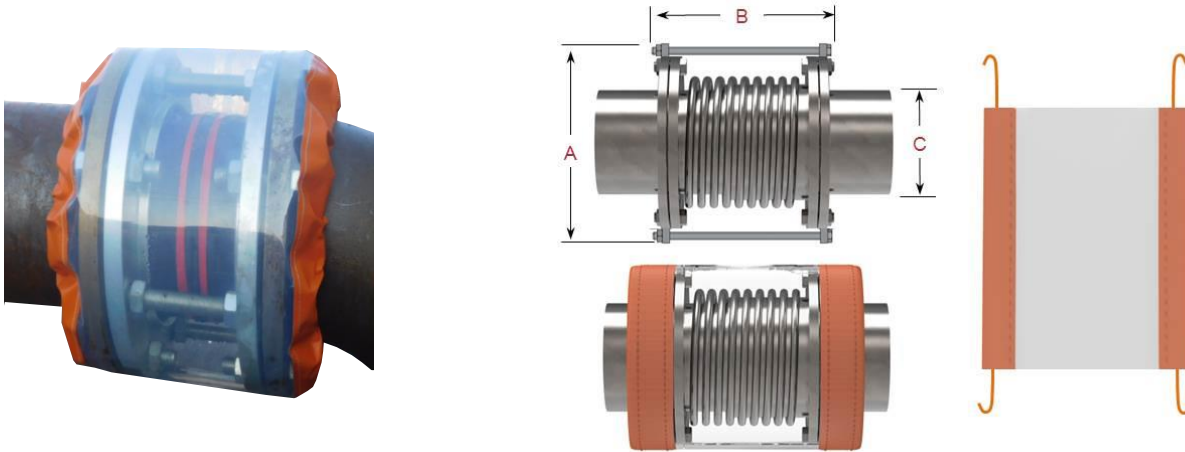

Specification

Material	:	PTFE + ECTFE
Stitching	:	PTFE
Draw strings	:	PTFE
Max. Temperature	:	150 Deg C
Flange Ratings	:	ANSI / DIN / BS
Sizes	:	½" to 48"
Leak Detection	:	Visual
Typical Applications	:	Oil (fuel,lube,seal, etc) Acids, Caustics, Corrosives

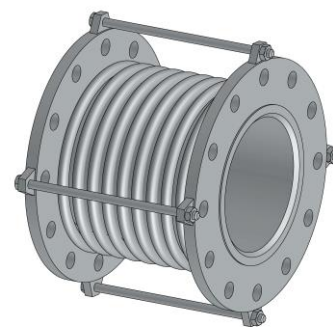

Flangeguards Ltd

Unit 2 Capricorn Centre,
Cranes Farm Road,
Basildon, Essex, SS143JA
0845 607 8227
sales@flangeguards.com

Delivery

Most shield materials and sizes are available ex-stock; however, in case of low availability delivery may take 2 - 4 working weeks.

Call 0845 607 8227 to confirm current stock levels – or e-mail sales@flangeguards.com